



# TQ Series Easy Booster

**Pipe In - Pipe Out  
Plug In  
Simple Professional Installation**



**Solid State Electronic  
Pressure Sensor**

**Motor  
&  
Pump  
Thermal  
Protected**

**Hydroflo Pumps USA, Inc.  
Fairview, Tennessee  
Granger, Indiana**

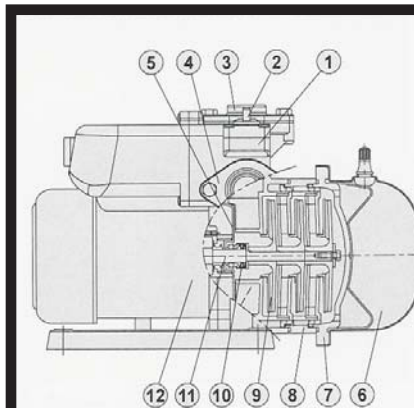

**Parts:**

No.	Part name
1	Pump casing
2	Filling plug
3	Outlet
4	Inlet
5	Seal seat
6	Diaphragm tank
7	Pump cover
8	Intermediate chamber
9	Impeller
10	Mechanical Seal
11	Shaft
12	Motor

# TQ Booster Series

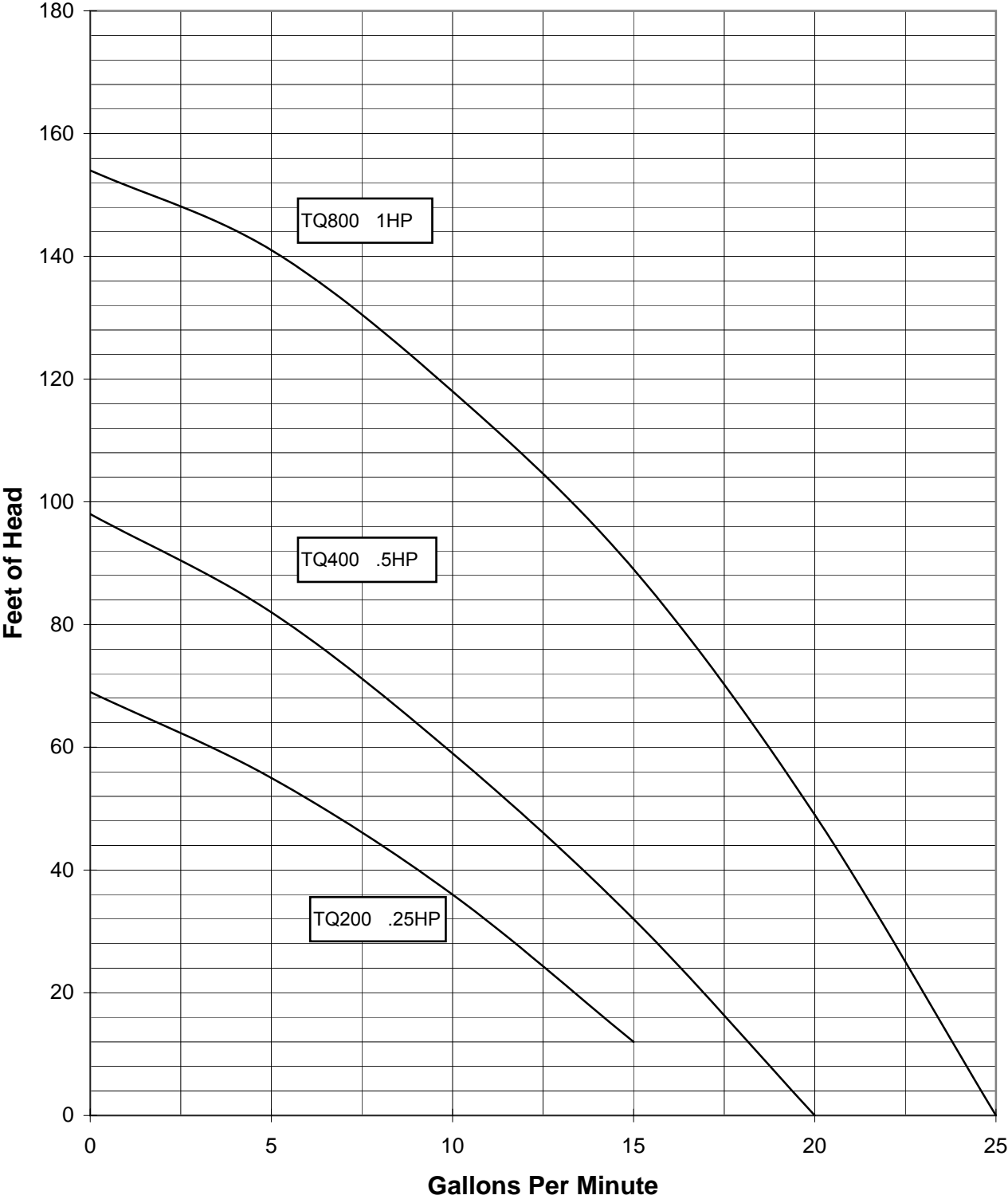

# TQ Booster Series

1500, 2200 & 3700

